



RS06

SKID STEER LOADER



**EXCELLENT PERFORMANCE
FULLY MEET THE NEEDS OF
VARIOUS USERS.**



EXCELLENT BASIC PERFORMANCE

ENGINE

Compact structure and powerful performance design. The engine adopts Kubota engine. At the same time, low Low fuel consumption, small vibration, low noise and consider. The environment has reached a high level.



POWERED BY **Kubota**

[DUAL-SPEED MODE] (standard configuration)

Combining two modes, let the loading machine not only “run quickly”, but also be “steady”, move faster between industrial sites or different work sites, save time



[PILOT OPERATING HANDLE]

It adopts pilot handle operation, which saves effort during work, operates more smoothly and is more efficient. It has the characteristics of strong maneuverability, fast construction speed, strong adaptability and good reliability, and is mostly used in working situations under various terrain conditions.

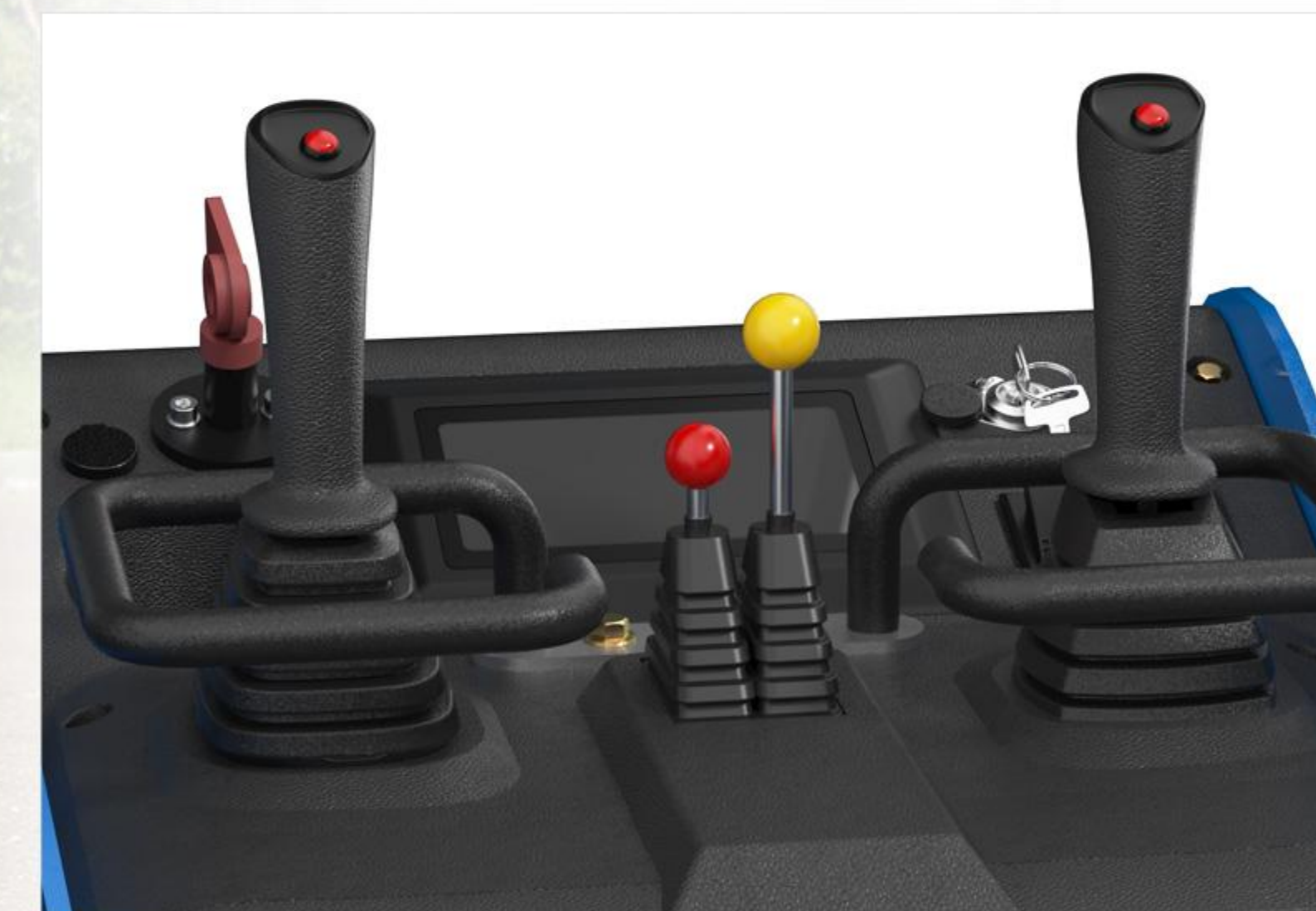

RS06 SKID STEER LOADER

Versatile in use, compatible with dozens of attachments, including augers, breakers, quick couplers, soil loosening tools, snowplows, 4-in-1 buckets, and dozer blades, meeting various work needs and enhancing operational efficiency and flexibility.

Detachable inspection panel is convenient for inspection and inspection of sprockets and travel motors can be more rigorous.

Equipped with a load-sensing multi-way valve, ensuring precise flow control and efficient power transmission, adapting to varying load conditions, and enhancing work efficiency and stability.



Equipped with two main auxiliary hydraulic lines and one unloading line, enabling quick connection of various attachments to enhance job flexibility and operational efficiency.

Equipped with the Kubota D1105 engine, delivering strong power, stable performance, low noise, and fuel efficiency for versatile job applications.

Equipped with a high-efficiency piston pump, delivering a flow rate of 84 L/min, providing stable high-pressure power output for precise control and outstanding performance in demanding work environments.

REPLACE ASSISTIVE DEVICEMODE (standard configuration)

When replacing auxiliary equipment such as hydraulic quick changers, breakers, and wood grabbers, you can easily replace them by pressing the button, which is convenient and quick.



MORE ACCESSORIES

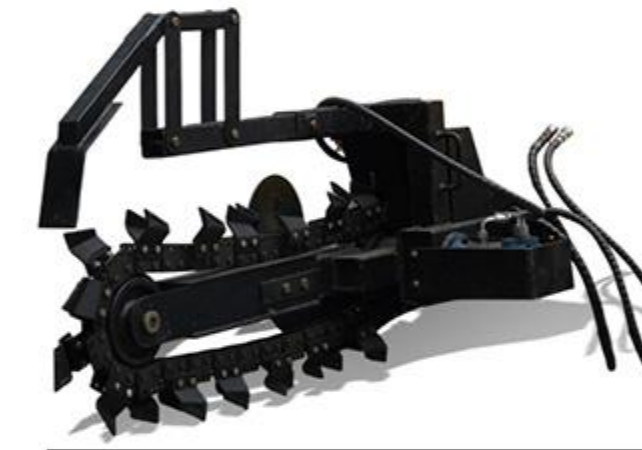

Trencher



Grass Clip



Snow Blade



Grapple



Digger



Auger



Pallet Fork



Rock Bucket



Hydraulic breaker



Rotary drill



Angle Broom



Standard Bucket



4in 1 Bucket



Pile Driver



Fork Clamp



Ditch Compactor

SHOW MORE DETAILS



LED lights

Six-bead configuration, sufficient brightness and uniform light, can illuminate a wide area in night/dark environment, helping the driver to observe the terrain, avoid obstacles, and operate accurately



Electronic display screen

The display screen can display various operating parameters of the machine in real time, such as engine speed, oil pressure, temperature, fuel consumption, etc., to help operators understand the equipment operating status in a timely manner



Leveling valve

Designed rocker arm and short linkage mechanism, vertical arm lift, single-handed operation. Added leveling valve, automatic leveling during bucket raising.



Add counterweights

Enhances overall machine stability (prevents tail lift) and heavy-load handling capabilities. Adds front and rear hooks for increased versatility.

- ◆ Broad vision and flexible control facilitate accurate loading and unloading of materials in narrow spaces
- ◆ In-situ steering can be achieved, making it easier to shuttle around crowded construction sites and construction sites;
- ◆ Enlarged and thickened bucket, not easy to corrode and rust, can quickly replace auxiliary tools, widely used and easy to operate;
- ◆ Big factory brand engine, strong power, stable operation, time-saving and labor-saving;
- ◆ The skid steer loader can be lifted to a high place with a crane, such as when building a building.



DETAILED PARAMETER CONFIGURATION

Envelope diagram

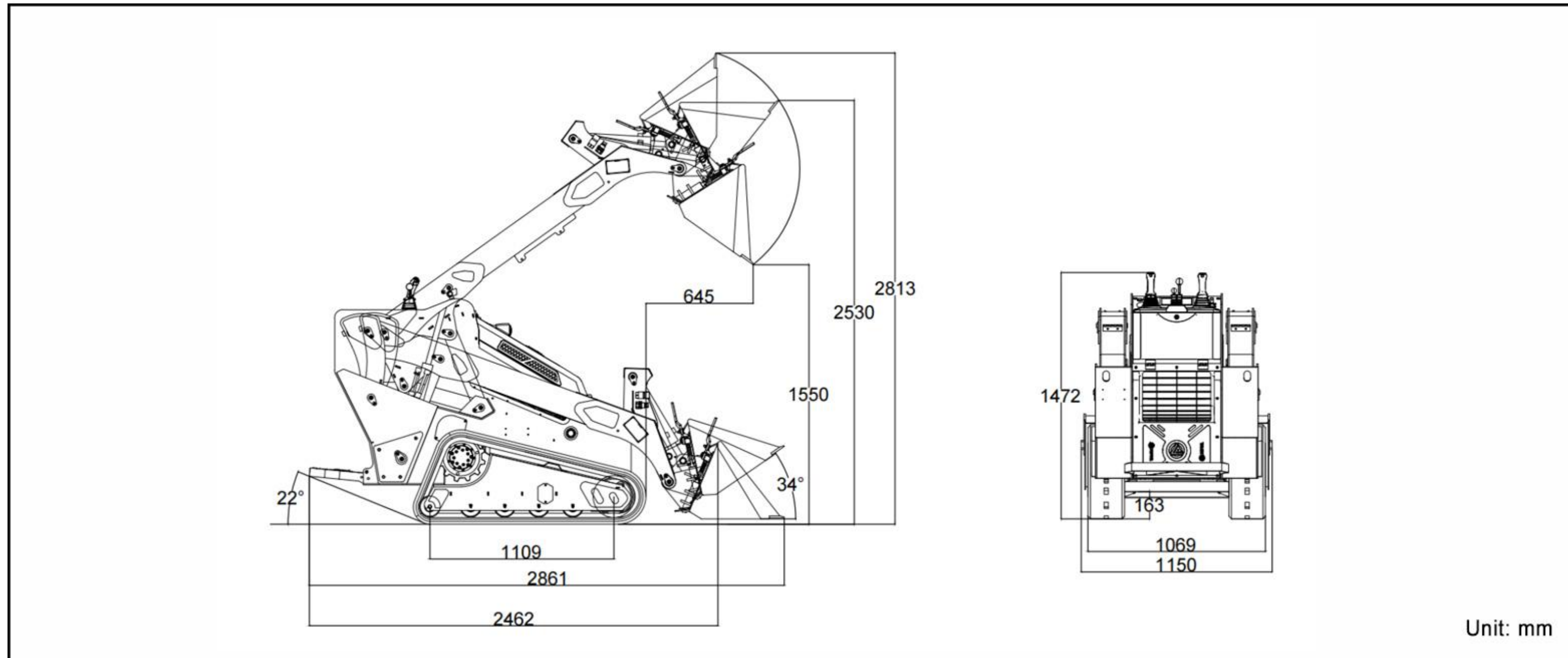

Product parameter

Basic performance parameter

Machine working weight	1475kg	3252lb
Bucket capacity	0.16m ³	5.7ft ³
Rated load mass (safe load)	300kg	661.4lb
Maximum load mass	600kg	1322.8lb
Travel speed low/high speed	0-3/0-6.5km/h	0-1.9/0-4mph
Gradeability	28%	28%
Ground pressure	32.5Kpa	4.7psi
Maximum unloading height	1550mm	61.2in
Maximum loading height	2530mm	99.7in
Maximum unloading distance	645mm	25.4in
Minimum ground clearance	163mm	6.4in

Body

Transport length - with bucket (mm)	2710mm	106.8in
Transport length - without bucket (mm)	2220mm	87.5in
Transport width (mm)	1150mm	45.3in
Transport height (mm)	1522mm	60in
Bucket width (mm)	1150mm	45.3in

POWERED BY

Kubota

ENGINE MODEL --- **D1105**

18.2 kw/3000rpm

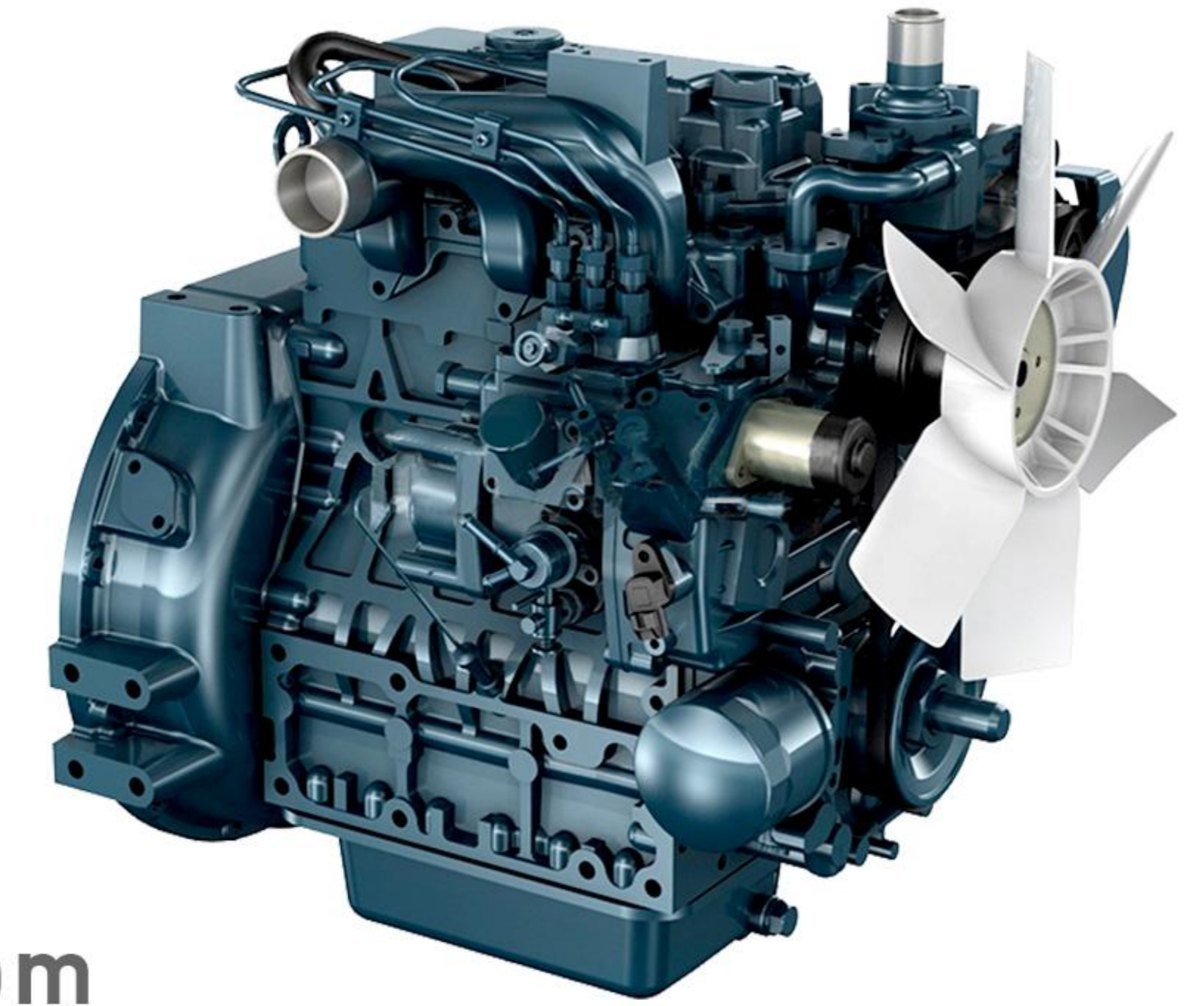

Engine

Engine brand	Kubota	Kubota
Engine model	D1105	D1105
Maximum horsepower	24.8ps	24.4hp
Maximum power	18.2kw	18.2kw
Maximum speed	3000rpm	3000rpm
Displacement	1.123L	0.297gal
Number of cylinders	3	3
Cooling method	Water-cooled	Water-cooled
Engine oil change amount	4L	1.057gal
Fuel form	Diesel	Diesel
Fuel grade	0/-10	0/-10
Theoretical fuel consumption	1.3-1.5	0.211-0.317gal

Hydraulic system

Main pump type/model	Plunger pump HP3VO45LA7DS_01SR-_VS1C12N00
Main pump brand	Hytek
Multi-way valve brand	Hytek
Multi-way valve	Load sensing multi-way valve
Travel hydraulic motor type	Two-speed travel motor

WE ARE RIPPA

Shandong Rippa Machinery Group Co., Ltd. is located in the Sixth Industrial Park, Jining high tech Zone, Shandong Province. It is a state-level high-tech enterprise with the right to import and export;

The company's staff are vigorous and enterprising, and constantly create the legend and glory of the rippa!



Shandong Rippa Machinery Group Co., Ltd.

Address: No. 39, Guang'an Road, Liuxing Sub-district Office, High-tech Zone, Jining City, Shandong Province.

Some specifications are based on engineering measurements and may deviate from actual conditions. Specifications are for comparison purposes only and are subject to change without notice. Specifications of individual RIPPA equipment will vary based on normal variations in design, manufacturing, operating conditions and other factors. Some pictures of RIPPA equipment are not limited to standard packages.



www.rippa.com